

5 to 30 Minute Timer

Description:

A switched timer for intervals of 5 to 30 minutes incremented in 5 minute steps.

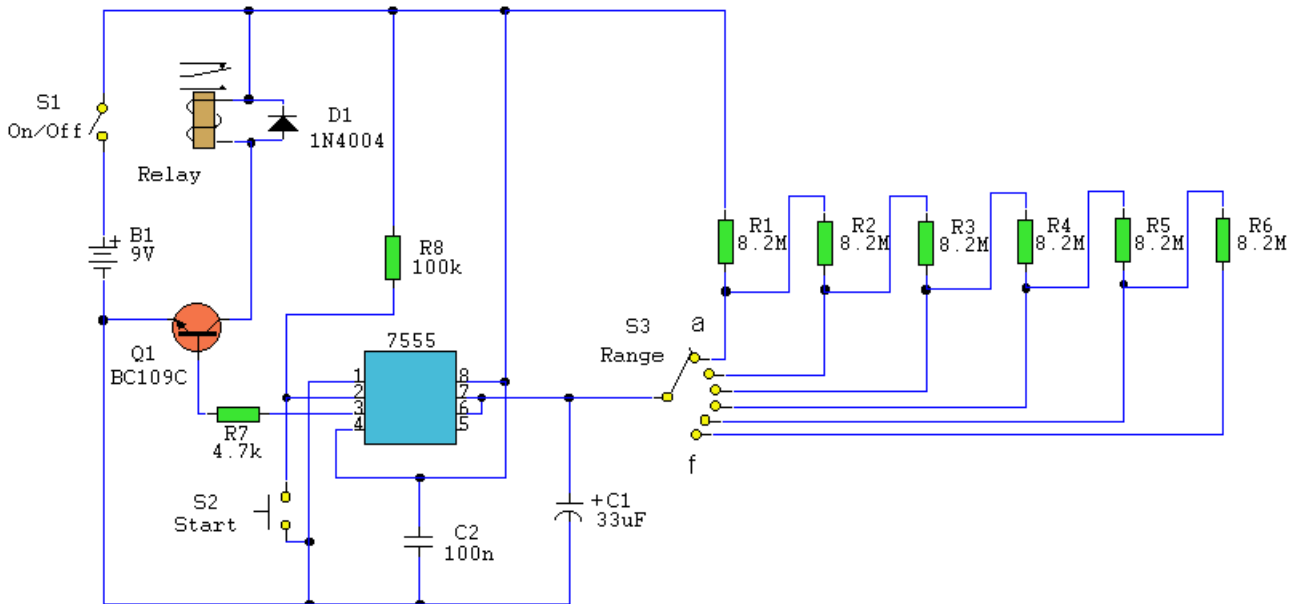

Notes:

Simple to build, simple to make, nothing too complicated here. However you must use the CMOS type 555 timer designated the 7555, a normal 555 timer will not work here due to the resistor values. Also a low leakage type capacitor must be used for C1, and I would strongly suggest a Tantalum Bead type. Switch 3 adds an extra resistor in series to the timing chain with each rotation, the timing period us defined as :-

$$\text{Timing} = 1.1 C_1 \times R_1$$

Note that R_1 has a value of 8.2M with S3 at position "a" and 49.2M at position "f". This equates to just short of 300 seconds for each position of S3. C_1 and R_1 through R_6 may be changed for different timing periods. The output current from Pin 3 of the timer, is amplified by Q1 and used to drive a relay.

Parts List:

- Relay 9 volt coil with c/o contact (1)
- S1: On/Off (1)
- S2: Start (1)
- S3: Range (1)
- IC1: 7555 (1)
- B1: 9V (1)
- C1: 33uF CAP (1)
- Q1: BC109C NPN (1)
- D1: 1N4004 DIODE (1)
- C2: 100n CAP (1)
- R6,R5,R4,R3,R2,R1: 8.2M RESISTOR (6)
- R8: 100k RESISTOR (1)
- R7: 4.7k RESISTOR (1)